

Series: GTHN, wheel Ø 75 - 250 mm

**Heavy duty drive wheels with hub keyway,
with Blickle Extrathane[®] polyurethane tread,
cast iron wheel centre**

👤 250 - 2000 kg



Treads: Made of Blickle Extrathane[®] polyurethane, firmly bonded, colour light brown, non-marking, 92° shore A, elastic, abrasion-resistant, high cut and tear propagation resistance, non-staining, floor-saving, low-noise operation, low rolling resistance, very good chemical connection with the wheel centre.

Wheel centres: Made of grey cast iron, very rugged, borehole and hub keyway in acc. with DIN 6885.

Lacquered - colour silver.
Detailed description: Page 46.

Wheels

Ref. No.	Wheel Ø (D) [mm]	Wheel width (T2) [mm]	Load capacity [kg]	Axle bore Ø (d) [mm]	Hub groove length (B) [mm]	Hub groove height (H) [mm]	Hub length (T1) [mm]
GTHN 75/20H7	75	40	250	20 H7	6 JS9	22,8	40
GTHN 100/20H7	100	40	320	20 H7	6 JS9	22,8	40
GTHN 100/25H7	100	40	320	25 H7	8 JS9	28,3	40
GTHN 127/25H7	125	50	500	25 H7	8 JS9	28,3	60
GTHN 127/30H7	125	50	500	30 H7	8 JS9	33,3	60
GTHN 140/25H7	140	50	620	25 H7	8 JS9	28,3	60
GTHN 140/30H7	140	50	620	30 H7	8 JS9	33,3	60
GTHN 150/25H7	150	50	650	25 H7	8 JS9	28,3	60
GTHN 150/30H7	150	50	650	30 H7	8 JS9	33,3	60
GTHN 160/25H7	160	50	700	25 H7	8 JS9	28,3	60
GTHN 160/30H7	160	50	700	30 H7	8 JS9	33,3	60
GTHN 180/25H7	180	50	800	25 H7	8 JS9	28,3	60
GTHN 180/30H7	180	50	800	30 H7	8 JS9	33,3	60
GTHN 200/25H7	200	50	900	25 H7	8 JS9	28,3	60
GTHN 200/30H7	200	50	900	30 H7	8 JS9	33,3	60
GTHN 202/35H7	200	80	1250	35 H7	10 JS9	38,3	80
GTHN 202/40H7	200	80	1250	40 H7	12 JS9	43,3	80
GTHN 251/30H7	250	50	1000	30 H7	8 JS9	33,3	60
GTHN 251/40H7	250	50	1000	40 H7	12 JS9	43,3	60
GTHN 252/40H7	250	80	1600	40 H7	12 JS9	43,3	80
GTHN 252/50H7	250	80	1600	50 H7	14 JS9	53,8	80
GTHN 253/40H7	250	100	2000	40 H7	12 JS9	43,3	100
GTHN 253/50H7	250	100	2000	50 H7	14 JS9	53,8	100

For further wheel Ø, refer to the following page.

Variants / Accessories



Further dimensions

Technical description page

Ref. No. extension

Available for wheel Ø [mm]

Upon request

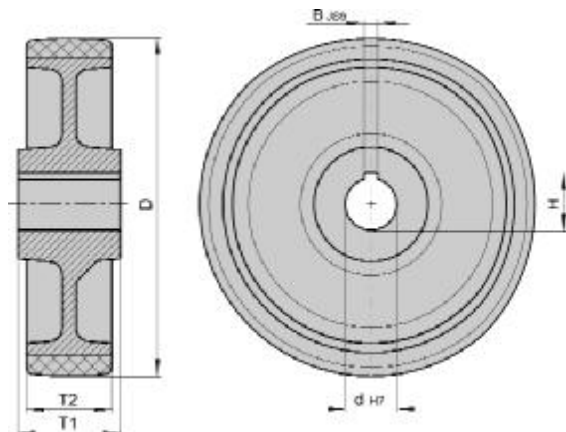

Series: GTHN, STHN wheel Ø 300 - 600 mm

**Heavy duty drive wheels with hub keyway,
with Blickle Extrathane® polyurethane tread,
cast iron or welded steel wheel centre**

1800 - 7500 kg



Treads: Made of Blickle Extrathane® polyurethane, firmly bonded, colour light brown, non-marking, 92° shore A, elastic, abrasion-resistant, high cut and tear propagation resistance, non-staining, floor-saving, low-noise operation, low rolling resistance, very good chemical connection with the wheel centre.

Wheel centres: GTHN series: Made of grey cast iron, very rugged,

STHN series: Very strong welded steel construction, borehole and hub keyway in acc. with DIN 6885. Lacquered - colour silver.

Detailed description: Page 46.

Wheels

Ref. No.	Wheel Ø (D) [mm]	Wheel width (T2) [mm]	Load capacity [kg]	Axle bore Ø (d) [mm]	Hub groove length (B) [mm]	Hub groove height (H) [mm]	Hub length (T1) [mm]
GTHN 302/40H7	300	80	1800	40 H7	12 JS9	43,3	80
GTHN 302/50H7	300	80	1800	50 H7	14 JS9	53,8	80
GTHN 304/40H7	300	100	2300	40 H7	12 JS9	43,3	100
GTHN 304/50H7	300	100	2300	50 H7	14 JS9	53,8	100
GTHN 362/40H7	360	75	2000	40 H7	12 JS9	43,3	75
GTHN 362/50H7	360	75	2000	50 H7	14 JS9	53,8	75
GTHN 400/40H7	400	60	1800	40 H7	12 JS9	43,3	60
GTHN 402/50H7	400	80	2400	50 H7	14 JS9	53,8	80
GTHN 402/60H7	400	80	2400	60 H7	18 JS9	64,4	80
GTHN 404/60H7	400	100	2900	60 H7	18 JS9	64,4	100
GTHN 404/70H7	400	100	2900	70 H7	20 JS9	74,9	100
GTHN 406/70H7	400	125	3600	70 H7	20 JS9	74,9	125
GTHN 406/80H7	400	125	3600	80 H7	22 JS9	85,4	125
STHN 500/100H7	500	150	5000	100 H7	28 JS9	106,4	150
STHN 600/120H7	600	200	7500	120 H7	32 JS9	127,4	200

12

Further information on the internet: www.blickle.de

Variants / Accessories



Further dimensions

Technical description page

Ref. No. extension

Available for wheel Ø [mm]

Upon request

